

Automata and Formal Languages — Endterm

- You have 120 minutes to complete the exam.
- Answers must be written in a separate booklet. Do not answer on the exam.
- Please let us know if you need more paper.
- Write your name and Matrikelnummer on every sheet.
- Write with a non-erasable pen. Do not use red or green.
- You are not allowed to use auxiliary means other than pen and paper.
- You can obtain 40 points. You need 17 points to pass.

Question 1 (1 + 2 + 1 + 1 + 1 + 1 + 1 = 8 points)

- a. Draw the LazyDFA over the alphabet $\Sigma = \{a, l, s\}$ for the pattern $p = aalsaal$.
- b. Give all residuals of the language $L = \{w : w \text{ contains an odd number of } ab\text{'s}\}$ over the alphabet $\Sigma = \{a, b, c\}$ and give for each non-empty residual the lexicographically smallest element of that residual.
- c. Give an NFA over the alphabet $\Sigma = \{a, b\}$ that recognises exactly the language of the following MSO formula φ :
$$\varphi = \forall X. \text{Even}(X) \rightarrow (\forall x \in X. \text{last}(x) \rightarrow Q_a(x))$$
- d. Consider the LTL formula $\varphi = \neg p \wedge \mathbf{X}(q \mathbf{U} r)$ over the set of atomic propositions $Ap = \{p, q, r\}$. Compute the satisfaction sequence $\text{sats}(\varphi, \sigma)$ for the computation $\sigma = \{r\}(\{p\}\{q, r\})^\omega$.
- e. Give a DRA over the alphabet $\Sigma = 2^{\{p, q\}}$ that recognises exactly all computations satisfying $\mathbf{FG}(p \mathbf{U} q)$.
- f. Prove or disprove: Every ω -regular language can be recognised by an NRA with a single initial state and a single Rabin pair.
- g. Prove or disprove: Let $\Sigma = \{a\}$ be a singleton alphabet. Then any language $L \subseteq \Sigma^\omega$ is ω -regular.

Question 2 (2 + 2 = 4 points)

Consider the following regular language L over the alphabet $\Sigma = \{a, b\}$:

$$L = \{w \in \Sigma^* : w \text{ has odd length and does not contain } aa\}$$

- a. Draw a DFA D recognising the language L , i.e. $L(D) = L$.
- b. Compute the regular expression r recognising the language L , i.e. $L(r) = L$, by applying the algorithm presented in the lecture and document each step of the algorithm.

Question 3 (1 + 3 = 4 points)

Let us define for any language $L \subseteq \Sigma^*$ the following operation:

$$\frac{1}{2}L := \{w \in \Sigma^* : \exists u \in \Sigma^*. |w| = |u| \wedge wu \in L\}$$

- a. Construct an NFA N' such that $L(N') = \frac{1}{2}L(N)$ where N is the following NFA with $\Sigma = \{a, b, c\}$:

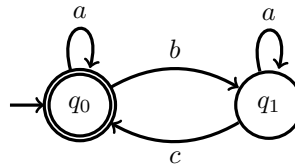

- b. Prove that if $L \subseteq \Sigma^*$ is a regular language, then $\frac{1}{2}L$ is also a regular language.

It suffices that you give a construction that takes an NFA $N = (Q, \Sigma, \delta, Q_0, F)$ for L as input and returns an NFA $N' = (Q', \Sigma, \delta', Q'_0, F')$ for $\frac{1}{2}L$ as output. Give definitions for Q' , δ' , Q'_0 and F' and explain the idea of the construction.

Hint: In the exercise classes you have seen a construction for the language $\sqrt{L} := \{w \in \Sigma^* : ww \in L\}$. You can adapt this construction to obtain a construction for $\frac{1}{2}L$.

Question 4 (2 + 1 + 2 = 5 points)

Consider the following program made of two processes (or agents) sharing a variable x initialised to `red`, which models a pedestrian traffic light in a *minimalistic way*:

<pre> while true: if $x = \text{red}$: $x \leftarrow \text{green}$ </pre>	<pre> while true: $x \leftarrow \text{red}$ </pre>
---	--

- Model the program by constructing a network of three automata (one for each process and one for the variable). Give the alphabet of each automaton. Each alphabet should be a subset of $\{x = \text{red}, x \neq \text{red}, x \leftarrow \text{red}, x \leftarrow \text{green}\}$.
- Construct the asynchronous product of the three automata obtained in (a). The alphabet of the automaton should be $\Sigma = \{x = \text{red}, x \neq \text{red}, x \leftarrow \text{red}, x \leftarrow \text{green}\}$.
- Let p be an atomic proposition that holds if and only if “variable x has value `green`”. Does **GF** p hold for every infinite execution of the program? Does **FG** p hold for some infinite execution of the program? Justify your answers.

Question 5 (3 + 3 = 6 points)

Recall that, given a state q of the master automaton for fixed-length languages over an alphabet Σ , and given $a \in \Sigma$, we let q^a denote the unique a -successor of q . Further, we denote by q_ϵ and q_\emptyset the states of the master automaton recognising $\{\epsilon\}$ and \emptyset , respectively.

Recall the definition of the symmetric difference of two languages L_1 and L_2 :

$$L_1 \Delta L_2 := \{w : (w \in L_1 \wedge w \notin L_2) \vee (w \notin L_1 \wedge w \in L_2)\}$$

- a. Fill the blanks in the algorithm for computing the state of the master automaton recognising the symmetric difference of the languages recognised by two given states. The alphabet is $\Sigma = \{a_1, a_2, \dots, a_m\}$.

Input: states q_1, q_2 with same length.

Output: state recognizing $L(q_1) \Delta L(q_2)$.

symmdiff(q_1, q_2):

```

if  $G(q_1, q_2)$  is not empty then return  $G(q_1, q_2)$ 
else if Blank 1 then return  $q_\emptyset$ 
else if Blank 2 then return  $q_\epsilon$ 
else
  for  $i = 1, \dots, m$  do
     $r_i \leftarrow$  Blank 3
   $G(q_1, q_2) \leftarrow \text{make}(r_1, \dots, r_m)$ 
return  $G(q_1, q_2)$ 

```

- b. Apply the algorithm to compute the state recognising $L(q_4) \Delta L(q_5)$ to the fragment of the master automaton shown below. Describe the tree of recursive calls, give the result of each call, and draw the resulting automaton. If you use optimisations described in the course, then describe them briefly.

Always recurse into the branch labelled with **a** first and then recurse into the branch labelled with **b**.

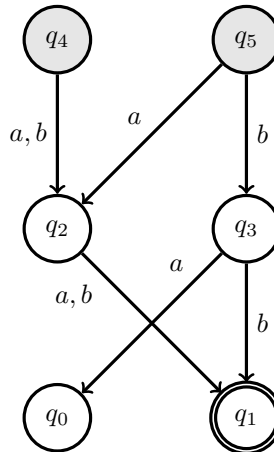

Question 6 (1 + 1 + 2 + 3 + 2 = 9 points)

A Büchi automaton is *weak* if every strongly connected component $S \subseteq Q$ is either contained in the accepting states ($S \subseteq F$) or is disjoint from the accepting states ($S \cap F = \emptyset$).

A weak, deterministic Büchi automaton D can be complemented by making accepting states non-accepting and non-accepting states accepting. Formally, let $D = (Q, \Sigma, \delta, q_0, F)$ be a weak DBA. Then the DBA $\overline{D} = (Q, \Sigma, \delta, q_0, Q \setminus F)$ accepts the complement-language, i.e. $L_\omega(\overline{D}) = \Sigma^\omega \setminus L_\omega(D)$.

Consider now the following two DBAs D_1, D_2 :

D_1 :

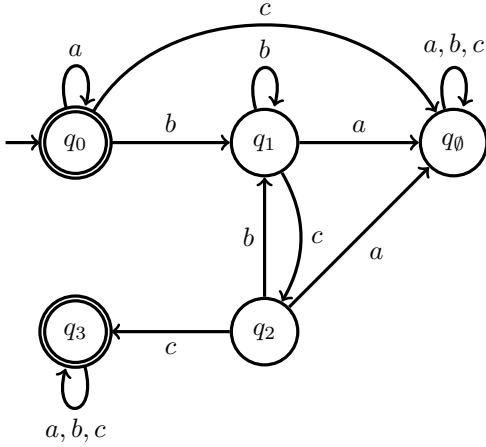

D_2 :

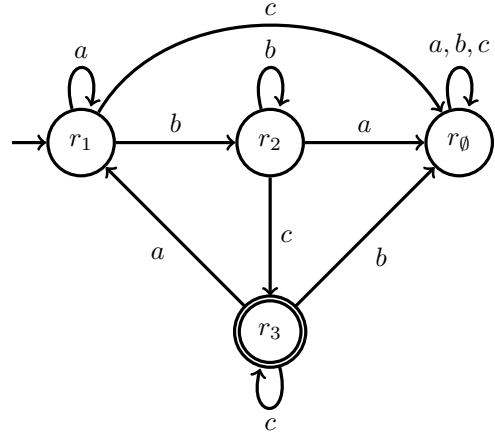

- Determine which of D_1 and D_2 are weak.
- Draw $\text{dag}((abc)^\omega)$ for D_1 and $\text{dag}((abc)^\omega)$ for D_2 .
- Decide if there exists an odd ranking for $\text{dag}((abc)^\omega)$ on D_1 and $\text{dag}((abc)^\omega)$ on D_2 . If an odd ranking exists, exhibit it and explain why it is an odd ranking. If none exists, argue why such a ranking does not exist.
- Prove that this complementation procedure is correct for weak DBAs, i.e. show that $L_\omega(D) = \Sigma^\omega \setminus L_\omega(\overline{D})$ holds for every weak DBA D .
- Show that the described complementation construction is not correct for weak NBAs. For this, give a weak NBA N such that $L_\omega(N) \neq \Sigma^\omega \setminus L_\omega(\overline{N})$ and an ω -word that belongs to $L_\omega(N) \Delta (\Sigma^\omega \setminus L_\omega(\overline{N}))$.

Question 7 (2 + 2 = 4 points)

Let $L \subseteq \Sigma^*$ be a language. We define the *infinite infix closure* (infix_∞) of a given language L as:

$$\text{infix}_\infty(L) = \{a_0 a_1 a_2 \dots \in \Sigma^\omega : \text{there are infinitely many } j \text{ such that } a_j a_{j+1} a_{j+2} \dots \in L \Sigma^\omega\}$$

For example, let $L = \{ab, cc\} \subseteq \{a, b, c\}^*$ be a language. Then we have $\{(aba)^\omega, abc^\omega\} \subseteq \text{infix}_\infty(L)$ and $\{abb^\omega, abc(cba)^\omega\} \cap \text{infix}_\infty(L) = \emptyset$.

- Prove that for any regular language L with $L \subseteq \Sigma^*$ the language $\text{infix}_\infty(L)$ is ω -regular.
- Exhibit an ω -regular language $L' \subseteq \Sigma^\omega$ such that there is no regular language $L \subseteq \Sigma^*$ with $L' = \text{infix}_\infty(L)$. Justify your answer.

Solution 1 (1 + 2 + 1 + 1 + 1 + 1 + 1 = 8 points)

a. LazyDFA for the pattern $p = aalsaal$:

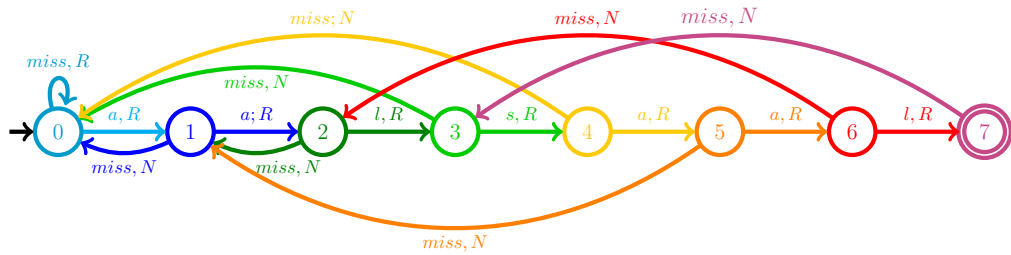

b. Minimal DFA for L :

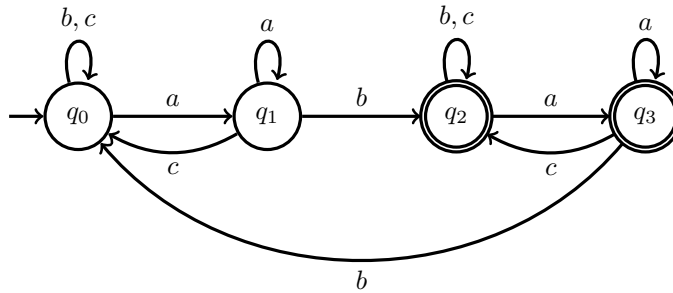

Thus there exist four residuals: L^ε , L^a , L^{ab} , and L^{aba} .

The corresponding lexicographically minimal elements are: ab , b , ε , and ε .

c. $L(\varphi) = \{w \in \Sigma^* : w \text{ has either odd length or even length where the last letter is } a \text{ or is the empty word}\}$.
Then a NFA for $L(\varphi)$ is:

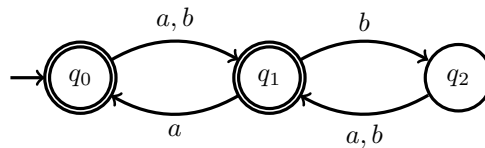

d. $\text{sats}(\varphi, \sigma) = \{\neg p, \neg q, r, q \mathbf{U} r, \neg \mathbf{X}(q \mathbf{U} r), \neg \varphi\}(\{p, \neg q, \neg r, \neg(q \mathbf{U} r), \mathbf{X}(q \mathbf{U} r), \neg \varphi\}\{\neg p, q, r, q \mathbf{U} r, \neg \mathbf{X}(q \mathbf{U} r), \neg \varphi\})^\omega$

e. DRA $D = (\{q_0, q_1, q_2\}, \Sigma, \delta, q_0, \{\{q_1\}, \{q_2\}\})$ for $L_\omega(\varphi)$:

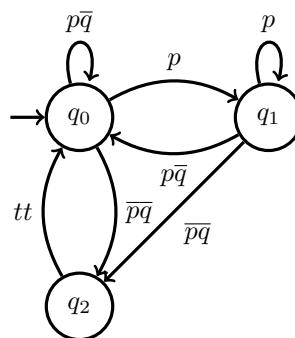

f. This statement is true. Every ω -regular language can be recognised by an NBA with a single initial state. This NBA can be reinterpreted as an NRA with the single Rabin-pair (F, \emptyset) .

g. This statement is true. $\Sigma^\omega = \{a^\omega\}$ Thus there exist only two languages with $L \subseteq \Sigma^\omega$: \emptyset and Σ^ω . Both can be trivially recognised by the ω -regular expressions: \emptyset and a^ω .

Solution 2 (2 + 2 = 4 points)

a. DFA for L :

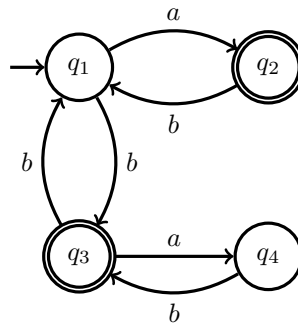

b. Step 1:

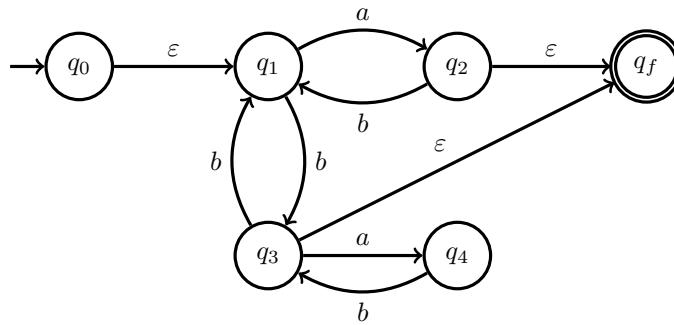

Step 2:

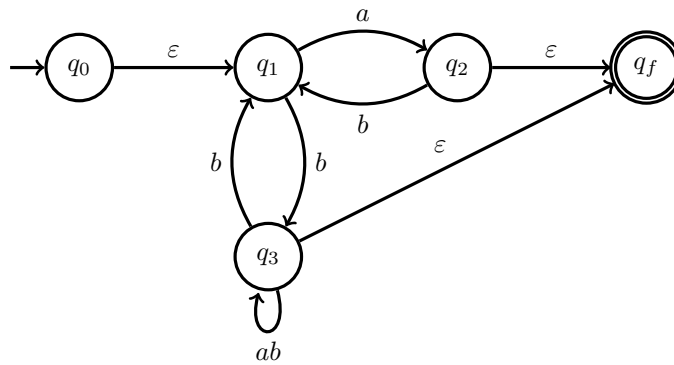

Step 3:

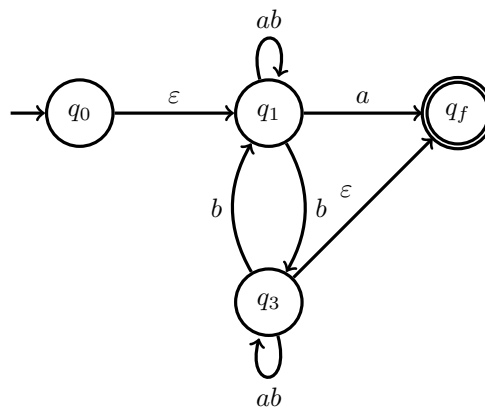

Step 4:

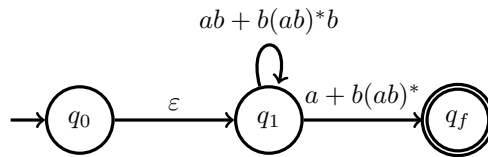

Step 5: $r = (ab + b(ab)^*b)^*(a + b(ab)^*)$

Solution 3 (1 + 3 = 4 points)

a. NFA N' for $\frac{1}{2}L(N)$:

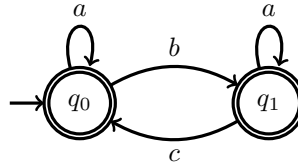

b. Let $N = (Q, \Sigma, \delta, Q_0, F)$ be an NFA for the given language $L \subseteq \Sigma^*$. Then we have $\frac{1}{2}L = L(N')$ for the NBA $N' = (Q \times Q \times Q, \Sigma, \delta', Q'_0, F')$ where we define:

- $\delta'((p, q, r), a) = \{(p', q, r') : p' \in \delta(q, a), r' \in \bigcup_{b \in \Sigma} \delta(r, b)\}$
- $Q'_0 = \{(p_0, q, q) : p_0 \in Q_0, q \in Q\}$
- $F' = \{(p, p, q_f) : p \in Q, q_f \in F\}$

Solution 4 (2 + 1 + 2 = 5 points)

a.

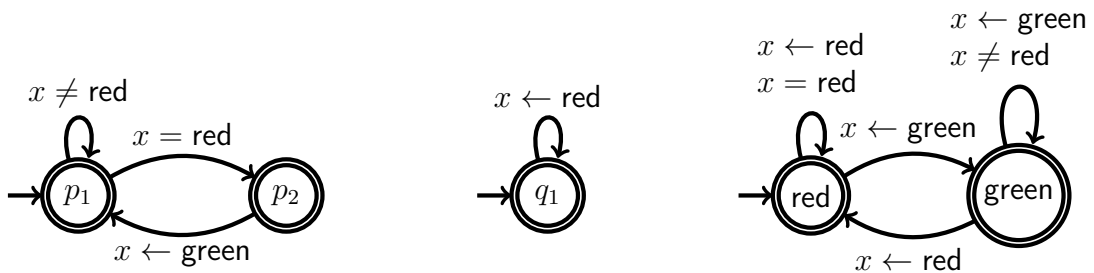

b.

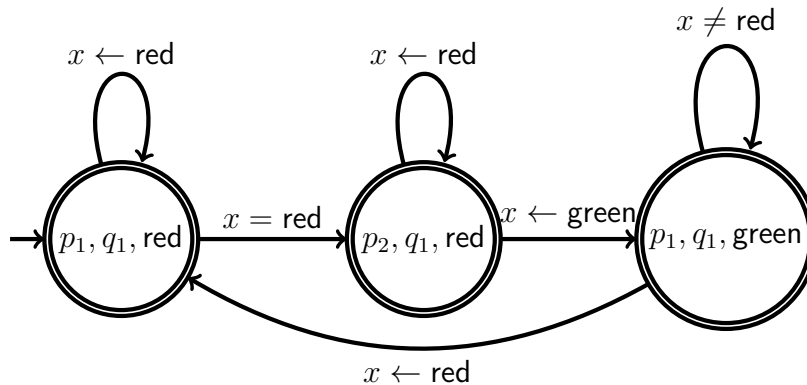

c. No. **GFp** means that x has the value green infinitely often and thus we visit the state (p_1, q_1, green) infinitely often. This does not hold, e.g., for the following infinite execution:

$$(p_1, q_1, \text{red}) \xrightarrow{x \leftarrow \text{red}} (p_1, q_1, \text{red}) \xrightarrow{x \leftarrow \text{red}} \dots$$

Yes. $\mathbf{FG}p$ means that x from some point on only the value **green** and thus we stays in the state $(p_1, q_1, \mathbf{green})$ from this point on. This does holds, e.g., for the following infinite execution:

$$(p_1, q_1, \mathbf{red}) \xrightarrow{x=\mathbf{red}} (p_2, q_1, \mathbf{red}) \xrightarrow{x\leftarrow\mathbf{green}} (p_1, q_1, \mathbf{green}) \xrightarrow{x\neq\mathbf{red}} (p_1, q_1, \mathbf{green}) \xrightarrow{x\neq\mathbf{red}} \dots$$

Solution 5 (3 + 3 = 6 points)

- a.
- Blank 1: $(q_1 = q_0 \wedge q_2 = q_0) \vee (q_1 = q_\varepsilon \wedge q_2 = q_\varepsilon)$
 - Blank 2: $(q_1 = q_0 \wedge q_2 = q_\varepsilon) \vee (q_1 = q_\varepsilon \wedge q_2 = q_0)$
 - Blank 3: $\text{symmdiff}(q_1^{a_i}, q_2^{a_i})$
- b. The tree of recursive calls is as follows:

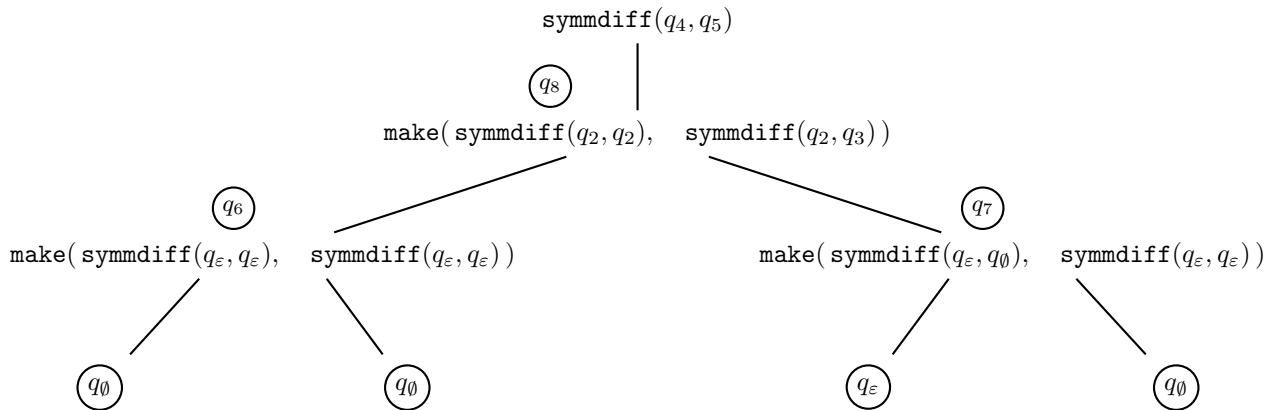

The resulting automaton is as follows:

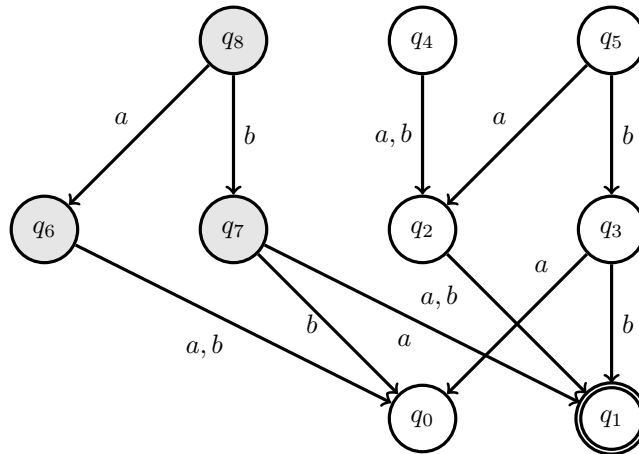

Solution 6 (1 + 1 + 2 + 3 + 2 = 9 points)

- a. D_1 is weak, since it has three (maximal) SCCs ($\{q_0\}$, $\{q_1, q_2\}$, and $\{q_3\}$) and the accepting states q_0 and q_3 . D_2 is not weak, since the SCC ($\{r_1, r_2, r_3\}$) is neither disjoint from F nor fully included in F .
- b. The run-dag for D_1 and for D_2 is infinite:

Run DAG for D_1 :

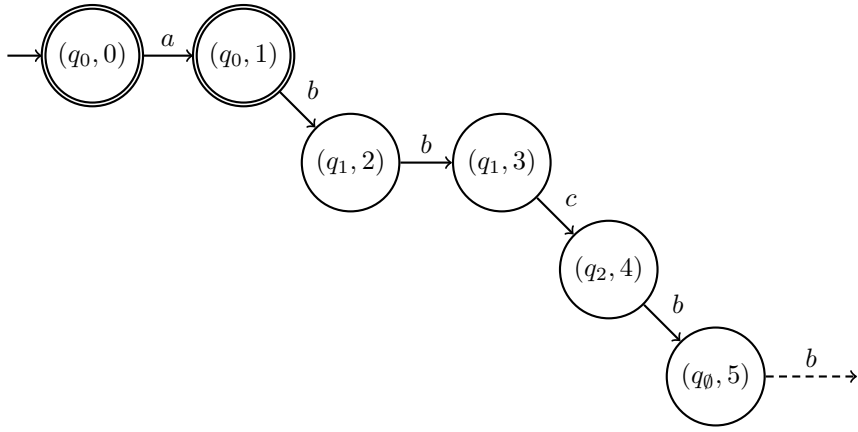

Run DAG for D_2 :

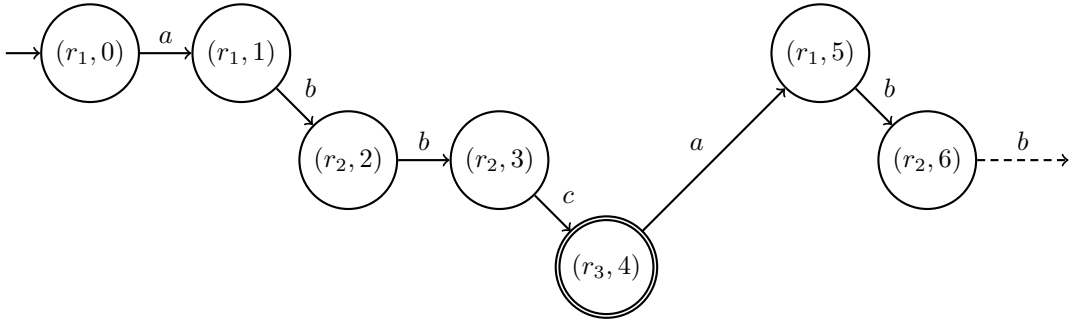

- c. D_1 : Yes, there exists the odd ranking R_w that maps $(q_0, 0)$ and $(q_0, 1)$ to 2 and all following states to 1.
 D_2 : No, there exists no odd ranking, since there exists only one run on the deterministic automaton and this run visits the accepting state infinitely often. Thus every ranking needs to give this state an even ranking, but since numbering needs to be decreasing and states need to be ranked by an odd number this will eventually terminate, since the lowest ranking is 0.
- d. Let D be an arbitrary, weak DBA. We need to prove (1) $L_\omega(D) \subseteq \Sigma^\omega \setminus L_\omega(\overline{D})$ and (2) $\Sigma^\omega \setminus L_\omega(D) \subseteq L_\omega(\overline{D})$.
 (1): Assume $w \in L_\omega(D)$. Then there exists an accepting run r on D . Since D and \overline{D} have the same structure, there exists also the run r on \overline{D} and it is the only one, since \overline{D} is deterministic. Observe further that the run r eventually stays within a SCC S and never leaves this SCC again. Because D is weak and r is accepting, we have $S \subseteq F$. Thus in \overline{D} this S is not accepting, thus r on \overline{D} is rejecting and we have $w \notin L_\omega(\overline{D})$. Hence $w \in \Sigma^\omega \setminus L_\omega(\overline{D})$.
 (2): Analogous to (1) and one needs simply to replace accepting with non-accepting in each step of the proof.
- e. Consider the following weak NFA N over the alphabet $\Sigma = \{a\}$. We have $a^\omega \in L_\omega(N)$, but also $a^\omega \in L_\omega(\overline{N})$.

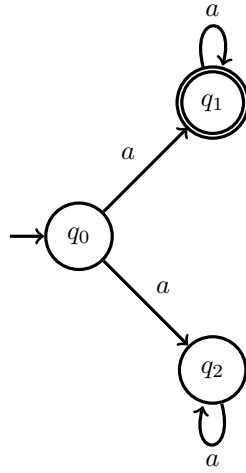

Solution 7 (2 + 2 = 4 points)

- a. Since L is regular, there exists a regular expression r such that $L = L(r)$. Then the ω -regular expression $r' = (\Sigma^* r \Sigma^*)^\omega$ describes $\text{infix}_\infty(L)$, i.e. $L_\omega(r') = \text{infix}_\infty(L)$.
- b. Observe that $\text{infix}_\infty(L)$ only depends on the “infinite” part of w , i.e. if $w \in \text{infix}_\infty(L)$ then also $w'w \in \text{infix}_\infty(L)$ for any $w' \in \Sigma^*$ and $w \in \Sigma^\omega$. Let $L' = \{ab^\omega\}$ be a ω -regular language. Assume there exists some $L \subseteq \Sigma^*$ such that $L' = \text{infix}_\infty(L)$. Due to our previous observation, we also have $aab^\omega \in \text{infix}_\infty(L)$, but this is a contradiction since $aab^\omega \notin L' = \text{infix}_\infty(L)$. Thus our assumption is wrong and we are done.